

# NO. 2 PRECISION CENTERLESS GRINDER

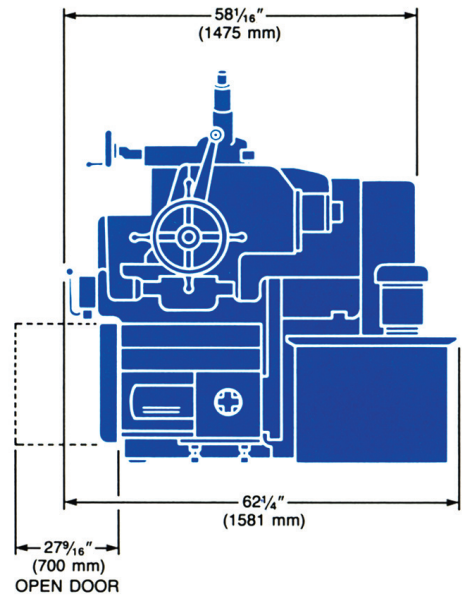
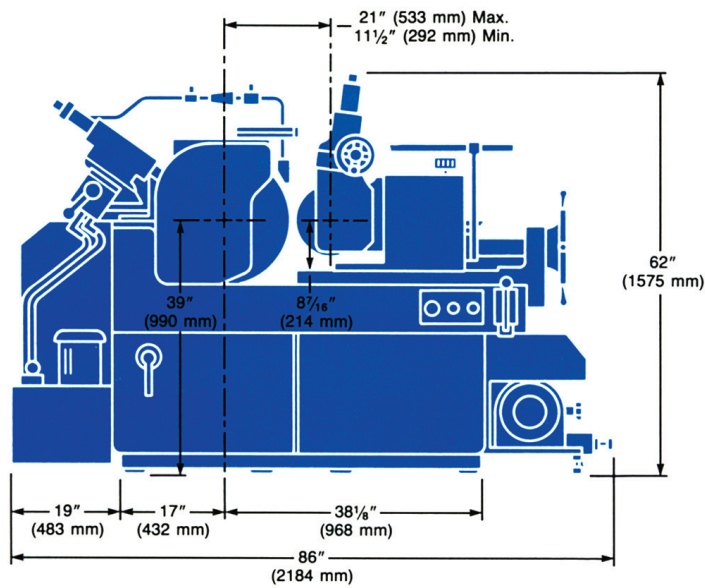

## Specifications

Capacities	8" Machine	10" Machine
<b>Work Diameter Range</b>		
Standard Workrest .....	.0625" to 3" (1.6 to 76mm)	0.0625" to 3" (1.6 to 76mm)
Low thrufeed Workrest .....	.2" to 3.75" (51 to 95mm)	2" to 3.75" (51 to 95mm)
<b>Grinding Wheel</b>		
Diameter x Width .....	.20" x 8" (508 x 203mm)	24" x 10" (610 x 254mm)
Bore .....	.12" (305mm)	12" (305mm)
Minimum Diameter .....	.15" (381mm)	17" (432mm)
Max. new wheel surface speed .....	.6500 sfpm (33m/s)	6500 sfpm (33m/s)
<b>Regulating Wheel</b>		
Diameter x Width .....	.12" x 8" (305 x 203mm)	12" x 10" (305 x 254mm)
Bore .....	.5" (127mm)	5" (127mm)
Minimum Diameter .....	.9" (229mm)	9" (229mm)
Max. new wheel surface speed .....	.Infinitely variable, 12 to 300 rpm	Infinitely variable, 12 to 300 rpm
<b>Drive Motor</b>		
Grinding Wheel .....	.15hp (12kw)	25hp (20kw)
<b>Coolant Equipment</b>		
Tank Capacity .....	.50 gal (189L)	50 gal (189L)
Pump Capacity .....	.30 gal/min (114L/min)	30 gal/min (114L/min)
<b>General Data</b>		
Floor Space .....	.88"x58"x62"(2235x1473x1575mm)	88"x58"x62"(2235x1473x1575mm)
Approximate Weight .....	.8500 lbs (3855 kg)	9000 lbs (4080 kg)